

CLM SERIES LIFTERS

COMMERCIALLY AVAILABLE LIFTERS THAT PROVIDE ALL THE DESIRED FEATURES APPLICATIONS DEMAND. CLM LIFTERS ARE COMPACT, ROBUST, AND EASY TO INSTALL. THEY ARE DESIGNED TO OPERATE SUCCESSFULLY IN HARSH ENVIRONMENTS.

AVAILABLE WITH PNEUMATIC, HYDRAULIC, OR ELECTRIC/SERVO ACTUATORS

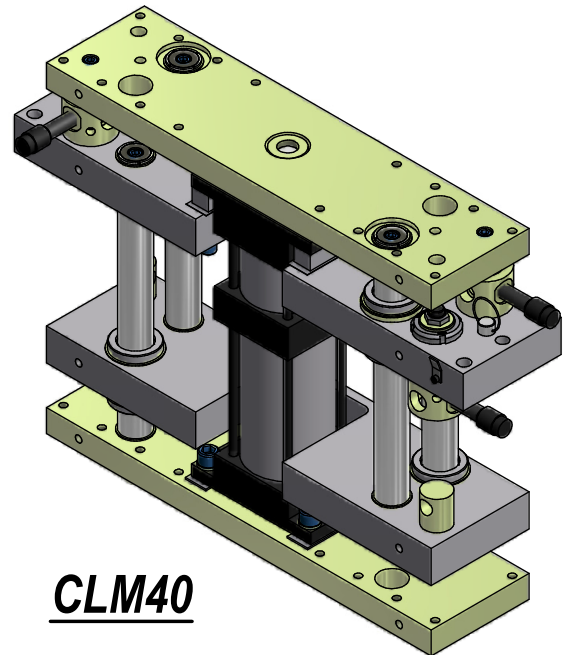

CLM40

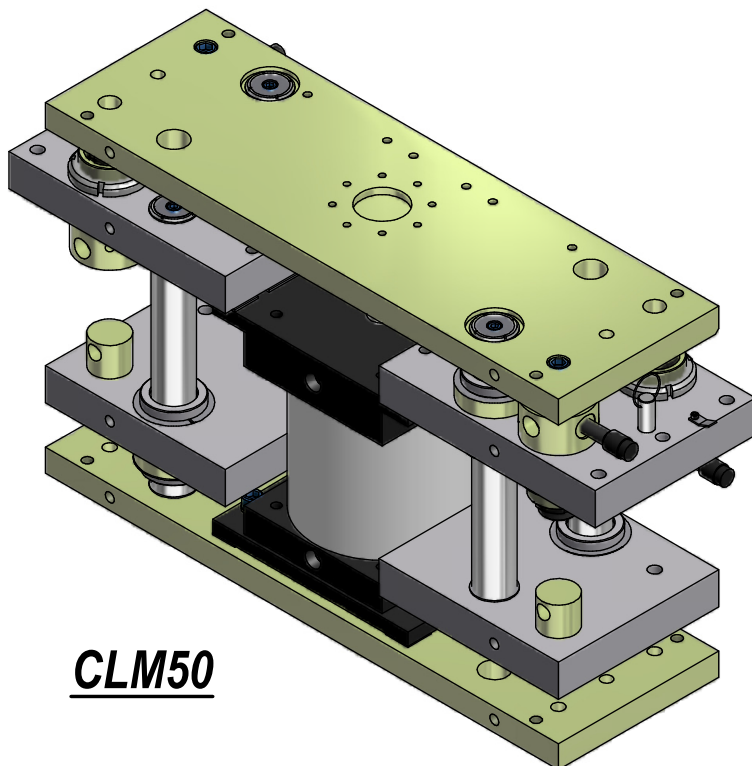

CLM50

LIFTER APPLICATIONS:

- WELD GUNS
- NUT RUNNERS
- GEO TOOLING
- MACHINING HEADS

ORDERING INFORMATION

CLM40-STROKE-{CYLINDER}

Stroke is 50mm - 1000mm

See Chart Below

CYL OPTION	CYL TYPE	CYL BORE	CYL BRAKE PORTS	MAIN CYL PORTS
-WEL1	NON-LOCK	4"	N/A	1/2 NPT
-WEL2	NON-LOCK	4"	N/A	#10 SAE
-WEL3	NON-LOCK	4"	N/A	1/2 G
-WEL4	LOCK	4"	1/4 NPT	1/2 NPT
-WEL5	LOCK	4"	#4 SAE	#10 SAE
-WEL6	LOCK	4"	1/4 G	1/2 G

ORDERING EXAMPLES:

TO ORDER UNIT WITH WELKER 4" BORE X 150mm STROKE LOCKING CYL W/ NPT PORTS,
AS SHOWN, ORDER AS:

#CLM40-150-WEL4

TO ORDER UNIT WITH WELKER 4" BORE X 150mm STROKE LOCKING CYL W/ G PORTS,
ORDER AS:

#CLM40-150-50-WEL6

CAPACITY:

60psi LOAD CAP. FOR STD LOCKING & NON-LOCKING AIR CYL:

365lbf (EXTEND) - 325lbf (RETRACT)

MIN. 60psi TO RELEASE LOCKING CYLINDERS

WEIGHTS IN LBS (WEIGHTS SHOWN ARE APPROXIMATE, WILL VARY WITH OPTIONS)

STROKE (mm)	100	200	300	400	500	600	700	800	900	1000
CLM40	252	261	269	278	287	295	304	313	321	330

*FOR HYDRAULIC AND SERVO
UNITS CONTACT WELKER.

(DO NOT SCALE DRAWING)

WELKER

ENGINEERED PRODUCTS

(800) 229-0890 www.welkerproducts.com

ORDERING INFORMATION

CLM50-STROKE-{CYLINDER}

Stroke is 50mm - 1000mm

See Chart Below

CYL OPTION	CYL TYPE	CYL BORE	CYL BRAKE PORTS	MAIN CYL PORTS
-WEL1	NON-LOCK	6"	N/A	3/4 NPT
-WEL2	NON-LOCK	6"	N/A	#12 SAE
-WEL3	NON-LOCK	6"	N/A	3/4 G
-WEL4	LOCK	6"	1/4 NPT	3/4 NPT
-WEL5	LOCK	6"	#4 SAE	#12 SAE
-WEL6	LOCK	6"	1/4 G	3/4 G
-WEL7	NON-LOCK	8"	N/A	3/4 NPT
-WEL8	NON-LOCK	8"	N/A	#12 SAE
-WEL9	NON-LOCK	8"	N/A	3/4 G

ORDERING EXAMPLES:

TO ORDER UNIT WITH WELKER 6" BORE X 150mm STROKE NON-LOCKING CYL W/ NPT PORTS, AS SHOWN, ORDER AS:

#CLM50-150-WEL1

TO ORDER UNIT WITH WELKER 6" BORE X 150mm STROKE LOCKING CYL W/ G PORTS, ORDER AS:

#CLM50-150-WEL6

CAPACITY:

6" BORE

60psi LOAD FOR STD LOCKING & NON-LOCKING AIR CYL:

850lbf (EXTEND) - 800lbf (RETRACT)

8" BORE

60psi LOAD FOR STD LOCKING AIR CYL:

1500lbf (EXTEND) - 1400lbf (RETRACT)

MIN. 60psi TO RELEASE LOCKING CYLINDERS

WEIGHTS IN LBS (WEIGHTS SHOWN ARE APPROXIMATE, WILL VARY WITH OPTIONS)

STROKE (mm)	100	200	300	400	500	600	700	800	900	1000
CLM50	557	569	581	593	605	617	629	641	653	665

(DO NOT SCALE DRAWING)



ENGINEERED PRODUCTS

(800) 229-0890 www.welkerproducts.com

GENERAL DIMENSIONS

CLM40

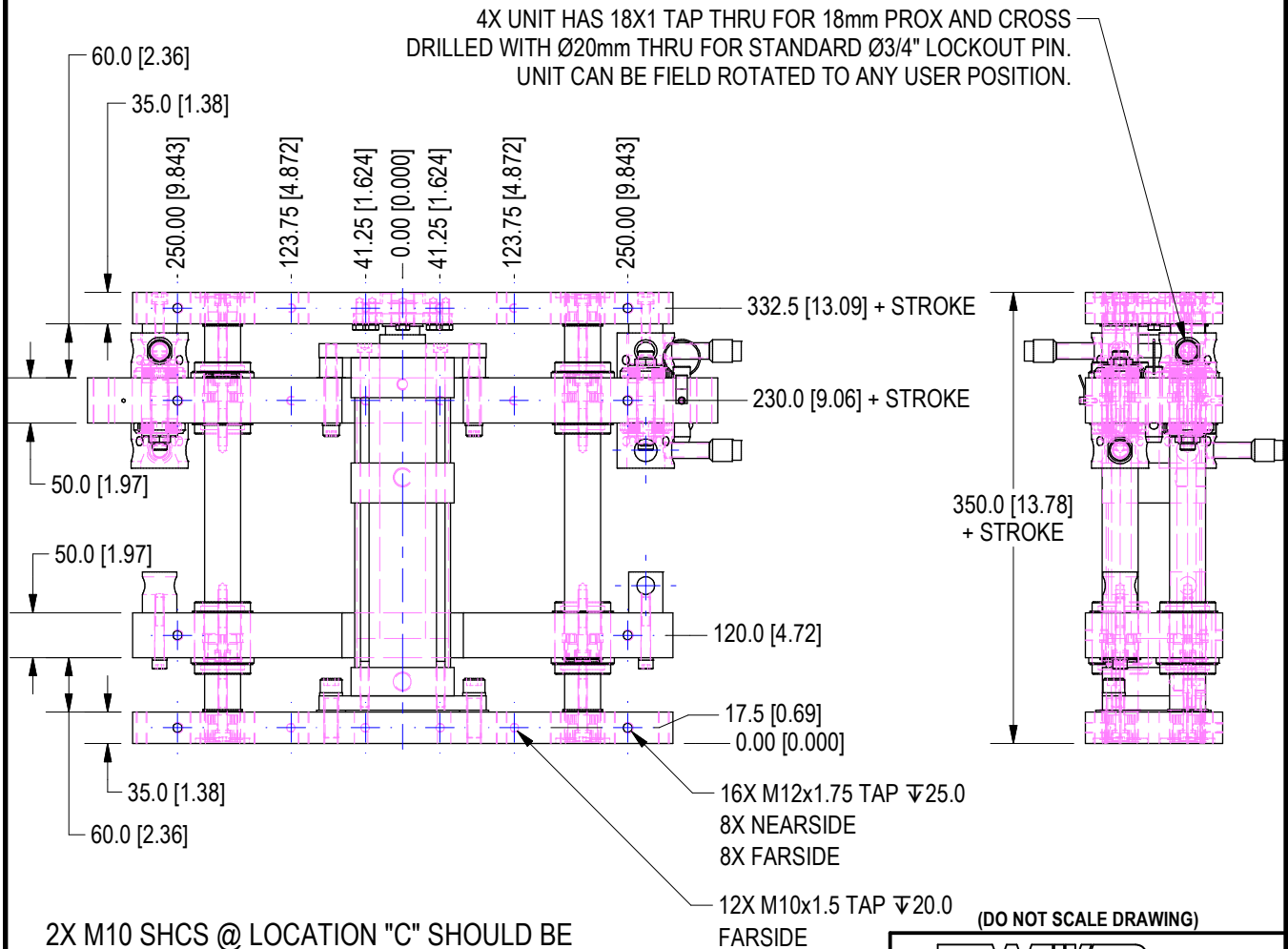
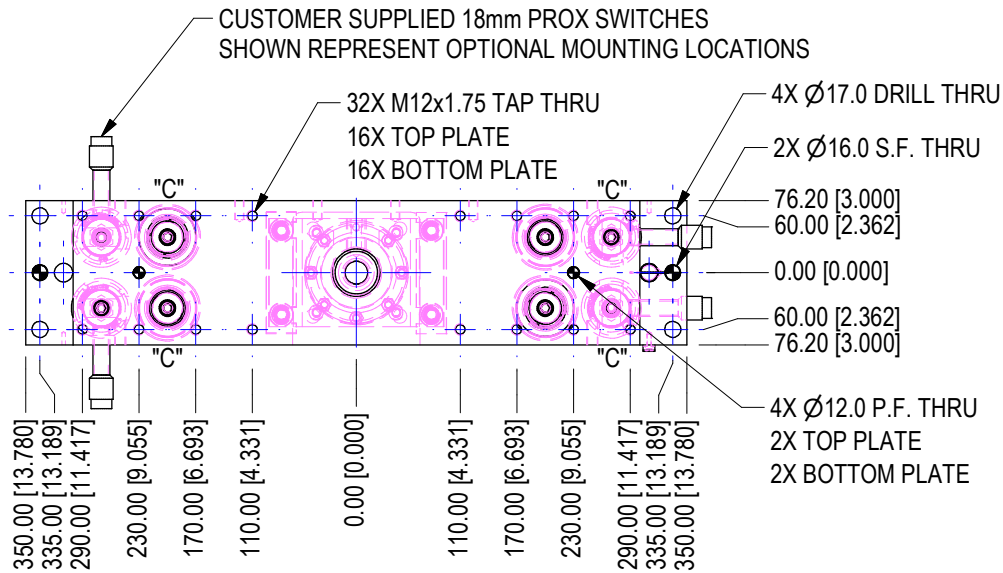

(DO NOT SCALE DRAWING)



ENGINEERED PRODUCTS

(800) 229-0890 www.welkerproducts.com

GENERAL DIMENSIONS

CLM50

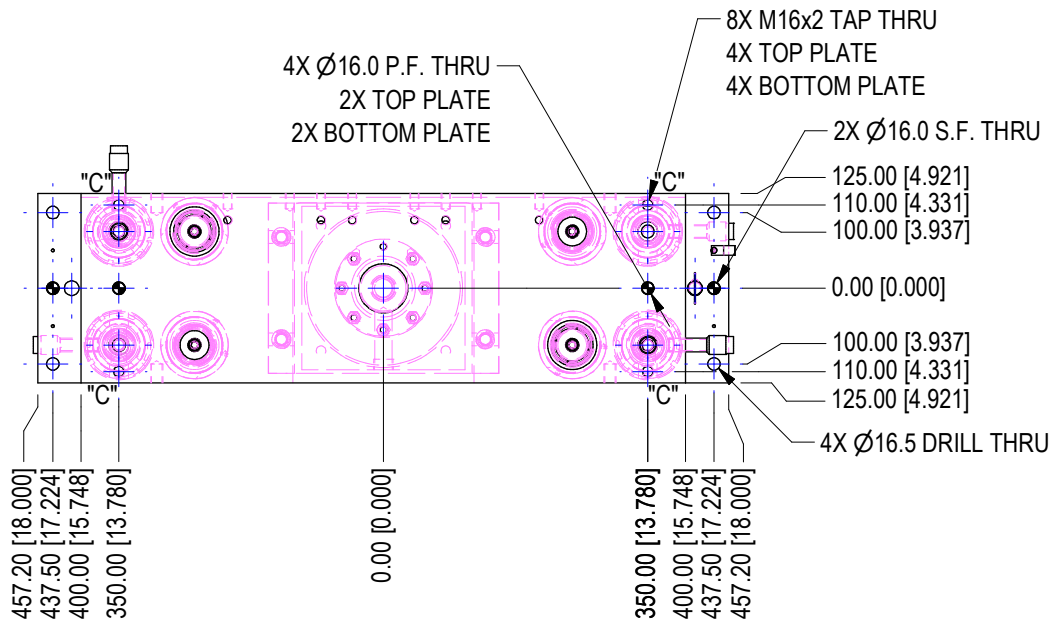

4X UNIT HAS 18X1 TAP THRU FOR 18mm PROX AND CROSS
DRILLED WITH Ø20mm THRU FOR STANDARD Ø3/4" LOCKOUT PIN.
UNIT CAN BE FIELD ROTATED TO ANY USER POSITION.

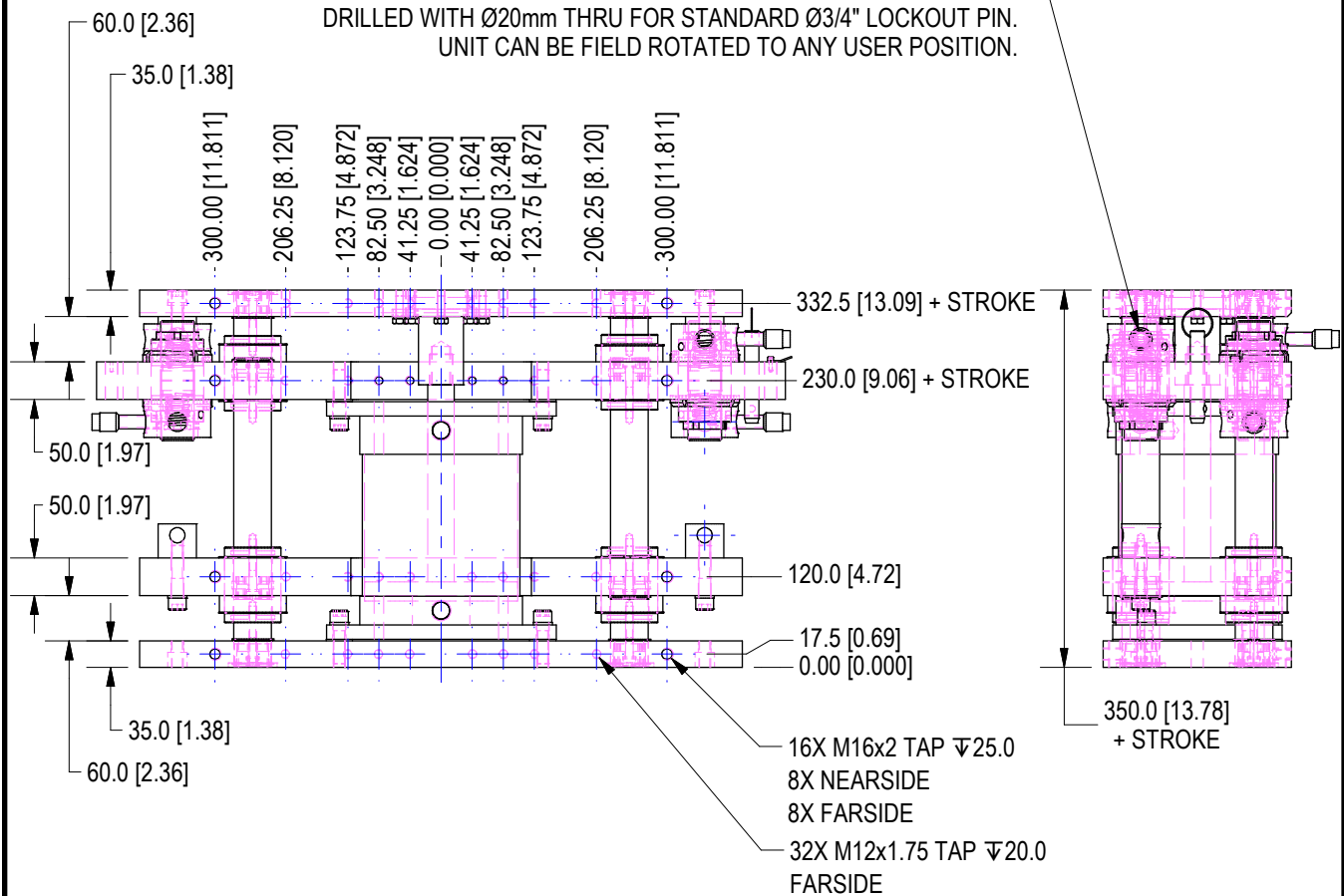

2X M10 SHCS @ LOCATION "C" SHOULD BE
LEFT CLEAR IF SHIMMING IN THE
RETRACTED POSITION IS REQ'D.

(DO NOT SCALE DRAWING)



ENGINEERED PRODUCTS

(800) 229-0890 www.welkerproducts.com